



# CASTER TOWN

Edmonton Calgary Vancouver Saskatchewan

- AIS slip-on pipe clamps are made of malleable iron castings which are free of sharp edges. They have either a hot dipped galvanized or fluorocarbon finish with case hardened set screws
- Fluorocarbon is a smoother, cleaner finish that allows the threads in the AIS clamps to be coated. This process is more environmentally friendly and will out last the galvanized finish by more than 2 to 1 ratio in salt spray testing
- AIS slip-on pipe clamps are designed to be used with standard pipe (Aluminum or Steel)
- Discover how easy it is to build strong structures such as railings, storage racks, work benches, outdoor shelters, boat docks, lighting grids, store fixtures, playground equipment, awning frames, solar panel frames and countless other applications using AIS clamps
- With the AIS clamps there is no welding, threading, drilling or bolting required for assembly. All connections are quick, strong and permanent, yet they can be quickly dismantled.
- Building contractors, plant operators and equipment manufacturers can save up to 70% on labor costs by using the AIS system. A tape measure, pipe cutter and hex wrenches are the basic tools needed for fabrication
- AIS clamps provide endless design opportunities for pipe construction. Both pipes and clamps can be powder coated in various colors

## STANDARD PIPE DIMENSIONS (SCH. 40 PIPE, FULL SIZE)

Size Ref.	Nominal Bore	I.D. (Rounded to the nearest 1/16)	O.D. (Rounded to the nearest 1/16)	LBS. PER FOOT	
				Steel	Alum
-5	3/4"	13/16"	1 1/16"	1.13	0.391
-6	1"	1"	1 5/16"	1.68	0.581
-7	1 1/4"	1 3/8"	1 11/16"	2.27	0.786
-8	1 1/2"	1 5/8"	1 7/8"	2.72	0.940
-9	2"	2 1/16"	2 3/8"	3.65	1.264

Note: AIS Clamps will also fit extra heavy and double extra heavy walled pipe sizes.  
Measurements may vary slightly

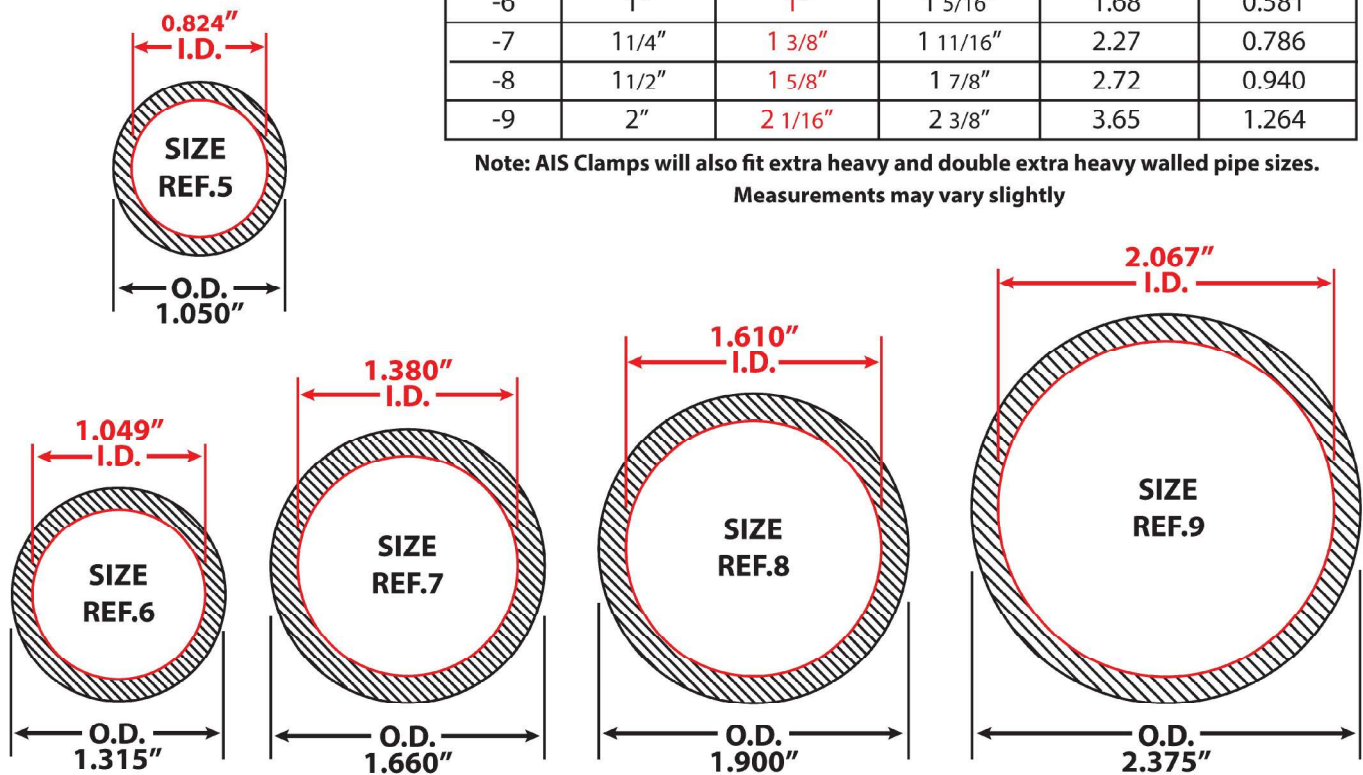

Measurements may vary

**A2 Single Socket Tee**

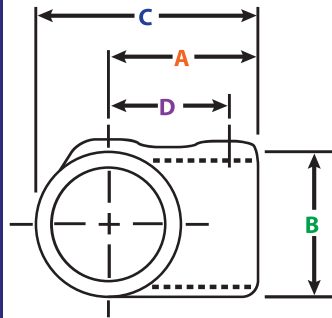

Size Ref.	DIMENSIONS (inches)				WT. LB.
	A	B	C	D	
A2-5	1.73	1.42	2.44	1.22	0.48
A2-6	2.13	1.73	2.99	1.50	0.79
A2-7	2.40	2.13	3.50	1.69	1.17
A2-7x8	2.72	2.36	3.82	2.01	1.41
A2-8	2.72	2.36	3.86	1.93	1.52
A2-8x7	2.56	2.13	3.78	1.85	1.34
A2-9	3.39	2.95	4.88	2.64	2.60

**A3 30°- 60° Single Socket Tee**

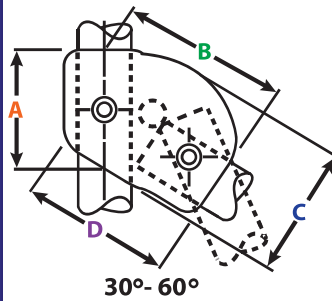

A3-6	2.17	2.95	2.56	2.48	0.84
A3-7	2.83	3.62	3.19	3.03	1.43
A3-8	3.07	4.02	3.62	3.50	2.07

**A4 Three Socket Tee**

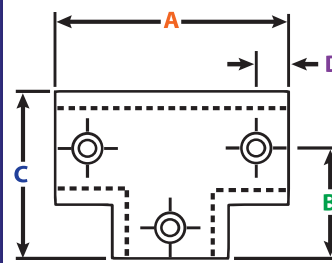

A4-5	3.46	1.69	2.44	0.51	0.86
A4-6	3.74	1.85	2.72	0.55	1.15
A4-7	4.72	2.36	3.43	0.71	1.96
A4-8	5.51	2.76	3.94	0.75	2.58
A4-9	6.73	3.35	4.80	0.75	4.28

**A6 90° Elbow**

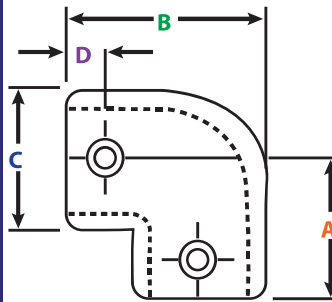

A6-5	1.65	2.36	1.46	0.51	0.60
A6-6	2.17	3.03	1.77	0.59	1.04
A6-7	2.40	3.46	2.13	0.71	1.61
A6-8	2.72	3.90	2.36	0.71	1.94
A6-9	3.39	4.84	2.91	0.75	3.35

**A7 165°- 105° Variable Elbow**

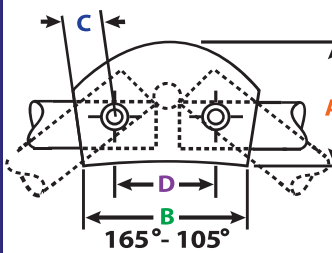

A7-6	2.60	2.28	0.55	1.73	0.97
A7-7	3.07	2.68	0.71	2.01	1.43
A7-8	3.50	3.11	0.75	2.44	1.83

Measurements may vary

### A8 Straight Coupling

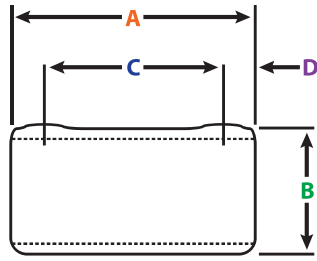

Size Ref.	DIMENSIONS (inches)					WT. LB.
	A	B	C	D	E	
A8-5	2.52	1.42	1.50	0.51		0.48
A8-6	3.54	1.77	2.32	0.59		0.90
A8-7	3.86	2.13	2.44	0.71		1.23
A8-8	3.86	2.44	2.44	0.71		1.52
A8-9	4.72	2.95	3.23	0.75		2.53

### A9 Internal Coupling

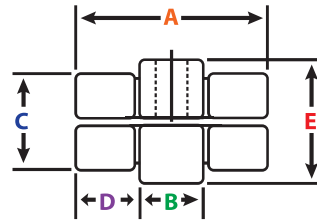

A9-6	3.07	0.83	0.98	1.10	1.34	0.60
A9-7	3.07	0.79	1.34	1.10	1.65	0.97
A9-8	3.07	0.98	1.61	1.02	1.93	1.39

### A10 Standard Flange

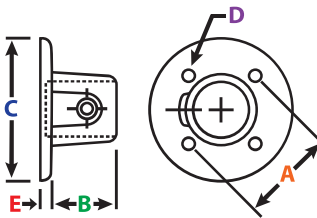

A10-5	2.48	1.89	3.19	0.20	0.20	0.79
A10-6	2.56	1.60	3.31	0.24	0.24	0.93
A10-7	2.91	1.80	3.74	0.28	0.28	1.40
A10-8	3.27	1.92	4.13	0.39	0.28	1.68
A10-9	3.90	2.20	5.04	0.39	0.28	2.56

### A12 Railing Flange

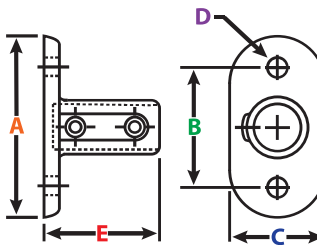

A12-5	4.45	2.99	2.40	0.43	3.19	1.56
A12-6	5.00	3.50	2.95	0.55	3.39	2.12
A12-7	5.59	4.09	3.15	0.55	3.43	2.80
A12-8	6.06	4.57	3.62	0.55	3.82	3.55
A12-9	6.50	4.92	3.86	0.71	4.76	5.50

### A14 Offset Railing Flange

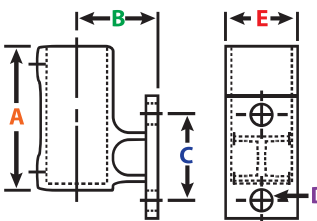

A14-6	4.09	2.48	2.60	0.55	1.89	2.05
A14-7	4.45	2.52	2.99	0.55	2.09	2.82
A14-8	4.45	2.36	3.43	0.55	2.36	3.42

Measurements may vary

**A15 Side Mount Flange**

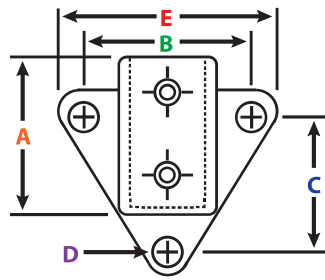

Size Ref.	DIMENSIONS (inches)					WT. LB.
	A	B	C	D	E	
A15-6	2.91	2.80	2.44	0.43	3.82	1.26
A15-7	3.27	3.27	2.83	0.39	4.21	1.79
A15-8	3.50	3.35	3.11	0.39	4.33	2.12

**A16 Standard Offset Railing Flange**

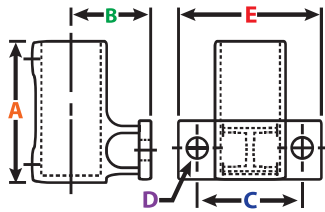

A16-6	4.09	2.52	2.60	0.55	3.78	2.16
A16-7	4.45	2.52	2.99	0.55	4.13	2.89
A16-8	4.45	2.52	3.39	0.55	4.57	3.46

**A17 Ground Soket Flange**

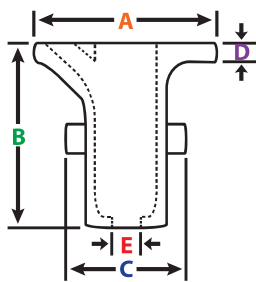

A17-6	5.47	5.20	4.06	0.24	0.51	3.42
A17-7	5.47	5.20	4.06	0.24	0.51	3.35
A17-8	5.47	5.20	4.06	0.24	0.51	3.28

**A18 Side Outlet Elbow**

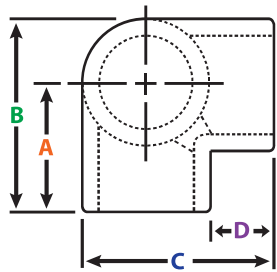

A18-5	1.77	2.56	2.56	1.06		0.95
A18-6	2.09	3.11	3.11	1.30		1.41
A18-7	2.60	3.82	3.82	1.61		2.22
A18-8	2.83	4.09	4.09	1.65		2.87
A18-9	3.27	4.84	4.84	1.84		4.47

**A20 Side Outlet Tee**

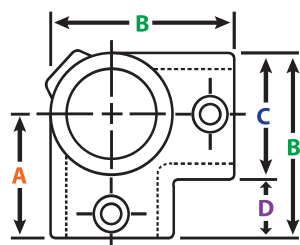

A20-5	1.81	2.60	1.42	1.10		0.73
A20-6	2.09	3.03	1.73	1.22		1.08
A20-7	2.56	3.66	2.09	1.50		1.70
A20-8	2.76	3.94	2.36	1.57		2.16
A20-9	3.35	4.80	2.91	1.85		3.35

Measurements may vary

**A21 Adjustable Side Outlet Tee**

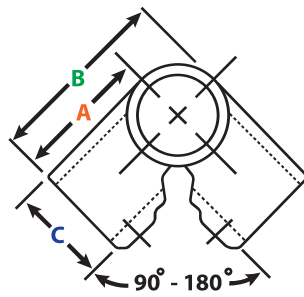

Size Ref.	DIMENSIONS (inches)					WT. LB.
	A	B	C	D	E	
A21-5	2.28	2.99	1.42			0.86
A21-6	2.52	3.46	1.73			1.32
A21-7	2.87	4.02	2.13			2.05
A21-8	3.27	4.45	2.40			2.58

**A22 Two Socket Cross**

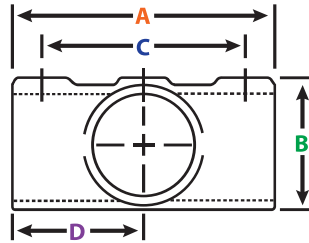

A22-5	3.39	1.46	2.36	1.69		0.66
A22-6	3.94	1.77	2.76	1.97		0.97
A22-7	4.76	2.13	3.31	2.36		1.95
A22-8	5.91	2.40	4.33	2.95		2.20
A22-9	6.77	2.95	5.31	3.39		3.50

**A23 30°-45° Adjustable Cross**

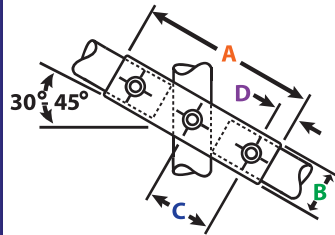

A23-6	5.71	1.77	2.28	0.55		1.34
A23-7	7.44	2.13	2.99	0.67		2.36
A23-8	8.50	2.40	3.46	0.71		3.20

**A24 Side Outlet Tee**

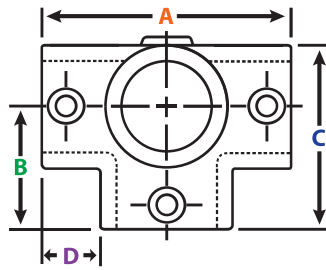

A24-5	3.31	1.73	2.44	0.91		0.84
A24-6	4.02	1.89	2.83	1.10		1.28
A24-7	4.88	2.40	3.50	1.34		1.96
A24-8	5.59	2.80	4.02	1.57		2.64
A24-9	6.73	2.92	4.80	1.89		4.34

**26 Four Socket Cross**

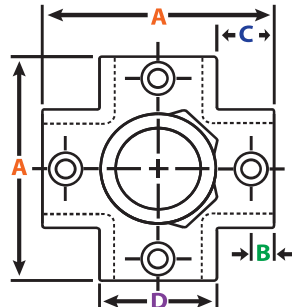

A26-6	4.21	0.51	1.22	1.73		1.90
A26-7	4.88	0.71	1.38	2.13		2.84
A26-8	5.59	0.71	1.61	2.36		3.55
A26-9	6.89	0.71	1.93	2.91		6.33

Measurements may vary

**A28 Offset Crossover**

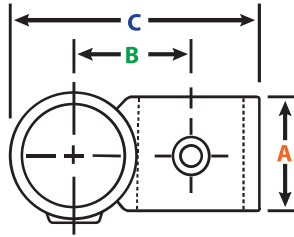

Size Ref.	DIMENSIONS (inches)					WT. LB.
	A	B	C	D	E	
A28-5	1.77	1.38	2.83			0.71
A28-6	1.81	1.61	3.43			0.86
A28-7	2.13	1.97	4.09			1.39
A28-8	2.36	2.17	4.65			1.79
A28-9	2.40	2.64	5.63			2.58
A28-8x6	2.17	1.85	3.98			1.43

**A30 Tee And Offset Cross Combination**

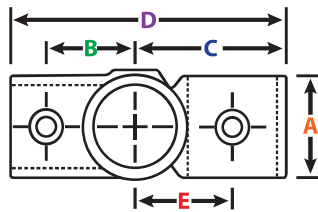

A30-5	1.77	1.10	2.00	3.74	1.38	0.84
A30-6	1.77	1.50	2.52	4.65	1.69	1.17
A30-7	2.17	1.69	3.07	5.43	2.01	1.85
A30-8	2.36	1.80	3.31	6.10	2.01	2.38
A30-9	3.07	2.56	4.25	7.60	2.60	4.30

**A32 Clamp-On Tee**

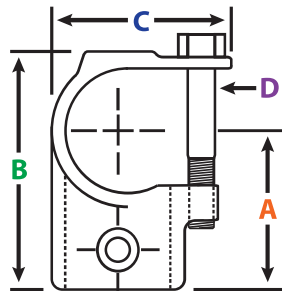

A32-6	2.13	3.35	2.44	0.35		0.86
A32-7	2.48	3.90	2.83	0.35		1.26
A32-8	2.91	4.37	3.11	0.35		1.65

**A34 Offset Rail Support**

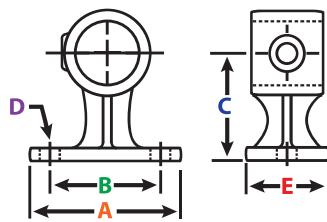

A34-5	3.07	2.24	2.24	0.31	1.77	0.86
A34-6	3.62	2.44	2.24	0.39	1.73	1.01
A34-7	4.37	3.31	2.32	0.39	1.97	1.45
A34-8	4.41	3.31	2.64	0.39	2.20	1.83

**A36 Single Swivel Socket Male**

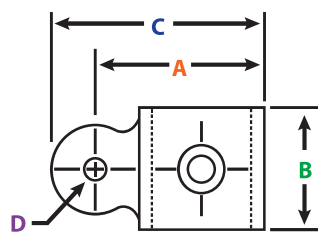

A36-5	2.32	1.54	3.07	0.39		0.51
A36-6	2.64	1.54	3.43	0.39		0.57
A36-7	2.99	1.77	3.78	0.39		0.77
A36-8	3.31	1.85	4.06	0.39		0.88
A36-9	3.82	2.09	4.61	0.39		1.30

Measurements may vary



**A38 Double Swivel Socket Male**

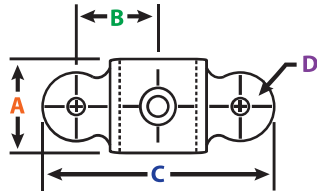

Size Ref.	DIMENSIONS (inches)					WT. LB.
	A	B	C	D	E	
A38-6	1.54	1.85	5.08	0.39		0.75
A38-7	1.77	1.97	5.39	0.39		0.97
A38-8	1.85	2.20	5.75	0.39		1.08

**A40 Corner Swivel Male**

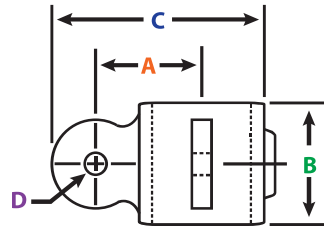

A40-6	1.77	1.54	3.43	0.39		0.77
A40-7	1.97	1.77	3.78	0.39		0.97
A40-8	2.13	1.85	4.13	0.39		1.12

**A42 Swivel Female**

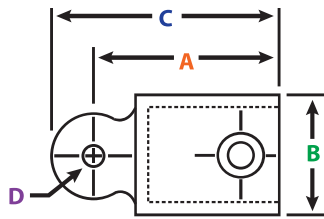

A42-5	2.40	1.42	3.11	0.39		0.64
A42-6	2.64	1.73	3.35	0.39		0.84
A42-7	2.91	2.13	3.62	0.39		1.12
A42-8	3.19	2.36	3.94	0.39		1.37
A42-9	3.50	2.91	4.29	0.39		2.01

**A44 Single Swivel Socket**

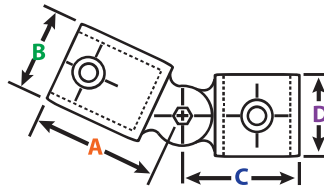

A44-5	2.40	1.42	2.32	1.54		1.19
A44-6	2.64	1.73	2.64	1.54		1.48
A44-7	2.91	2.13	2.99	1.77		1.98
A44-8	3.19	2.36	3.31	1.85		2.31
A44-9	3.50	2.91	3.82	2.09		3.37

**A46 Double Swivel Socket**

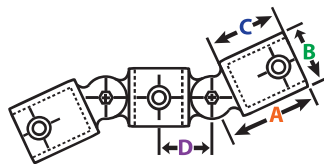

A46-6	2.64	1.73	1.42	1.69		2.71
A46-7	2.91	2.13	1.69	1.97		3.37
A46-8	3.19	2.36	2.01	2.20		3.97

Measurements may vary

**A48 Corner Swivel Socket**

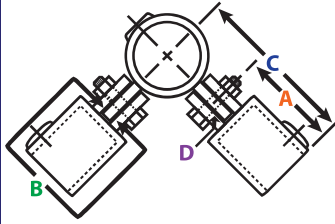

Size Ref.

DIMENSIONS (inches)

WT. LB.

Size Ref.	DIMENSIONS (inches)					WT. LB.
	A	B	C	D	E	
A48-6	2.64	0.39	4.41	0.39		2.53
A48-7	2.91	0.39	4.76	0.39		3.42
A48-8	3.19	0.39	5.28	0.39		4.06

**A50 Swivel Flange Plate**

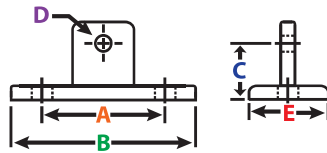

A50

3.31	4.41	1.38	0.39	1.81	0.77
------	------	------	------	------	------

**A52 Swivel Flange**

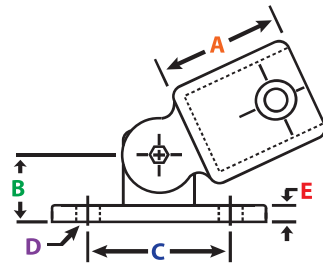

A52-5

2.40	1.38	3.31	0.47	0.28	1.50
------	------	------	------	------	------

A52-6

2.64	1.38	3.31	0.47	0.28	1.68
------	------	------	------	------	------

A52-7

2.91	1.38	3.31	0.47	0.28	1.98
------	------	------	------	------	------

A52-8

3.19	1.38	3.31	0.47	0.28	2.20
------	------	------	------	------	------

A52-9

3.50	1.38	3.31	0.47	0.28	2.84
------	------	------	------	------	------

**A54 Side Outlet Elbow & Tee Combination**

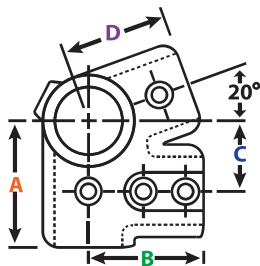

A54-6

2.87	2.83	1.57	1.97		1.76
------	------	------	------	--	------

A54-8

3.66	3.19	2.17	2.68		3.13
------	------	------	------	--	------

**A56 Side Outlet Tee & Elbow Combination**

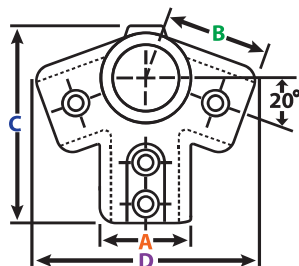

A56-6

1.77	2.13	4.06	4.61		1.52
------	------	------	------	--	------

A56-8

2.36	2.68	5.28	5.87		2.73
------	------	------	------	--	------



Measurements may vary

**A58 Collar**

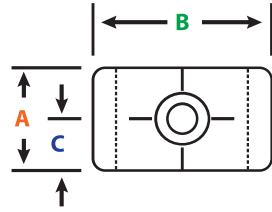

Size Ref.	DIMENSIONS (inches)					WT. LB.
	A	B	C	D	E	
A58-6	0.94	1.73	0.50			0.24
A58-7	1.10	2.13	0.55			0.37
A58-8	1.10	2.36	0.55			0.42
A58-9	1.10	2.91	0.55			0.60

**A60 Eye Fitting**

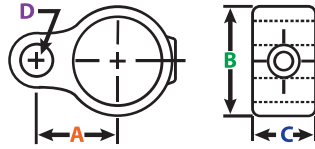

A60-6	1.30	1.73	0.94	0.55		0.42
A60-7	1.50	2.09	1.10	0.55		0.60
A60-8	1.65	2.36	1.10	0.55		0.66

**A62 Pin Fitting**

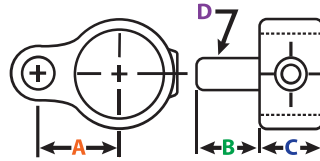

A62-6	1.30	0.94	0.94	0.51		0.55
A62-7	1.50	1.10	1.10	0.51		0.73
A62-8	1.65	1.10	1.10	0.51		0.79

**A64 Hook Fitting**

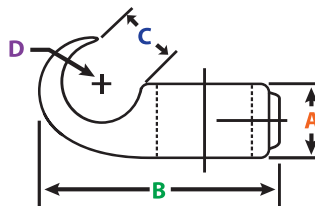

A64-6	0.94	3.39	0.75	0.87		0.42
A64-7	1.10	3.82	0.75	0.91		0.55
A64-8	1.10	4.09	0.67	0.91		0.66

**A66 Offset Crossover**

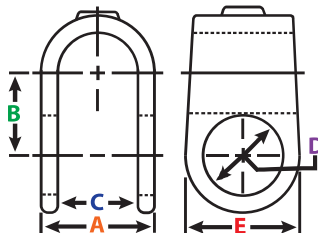

A66-5x5	1.78	1.11	1.12	1.09	1.64	0.56
A66-6x6	2.06	1.37	1.37	1.35	2.00	0.80
A66-7x6	2.70	1.55	1.73	1.35	2.00	0.95
A66-7x7	2.70	1.65	1.73	1.69	2.52	1.32
A66-8x7	2.70	1.68	1.95	1.69	2.53	1.55
A66-8x8	2.79	1.75	1.95	1.94	2.75	1.70



Measurements may vary

**A68 Plastic End Cap**

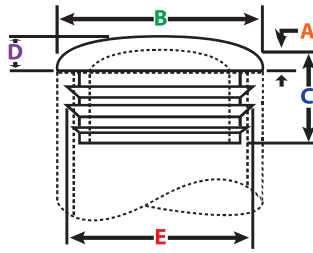

Size Ref.	DIMENSIONS (inches)					WT. LB.
	A	B	C	D	E	
A68-5	0.14	1.08	0.63	0.21	0.90	0.005
A68-6	0.17	1.31	0.71	0.23	1.11	0.01
A68-7	0.18	1.66	0.87	0.25	1.44	0.02
A68-8	0.18	1.85	0.94	0.27	1.70	0.03
A68-9	0.19	2.42	0.98	0.32	2.15	0.05

**A73 Ratchet (3/8" Drive)**



**A76 Hex. Allen Key**



1/4" Long      5/16" Long  
1/4" short    5/16" short

**A77 Ratchet Socket**



**A78 Set Screw**



1/4"                      3/8"

**A79 Rota - Lock**

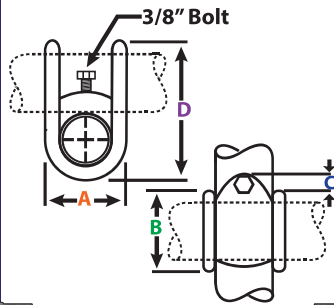

Size Ref.	DIMENSIONS (inches)					WT. LB.
	A	B	C	D	E	
A79-6	2.13	2.13	0.39	3.46		0.88
A79-7	2.48	2.48	0.51	4.25		1.26
A79-8	2.72	2.72	0.51	4.61		1.48
A79-9	3.23	3.23	0.63	5.59		2.16

**A84 Swivel Tee**

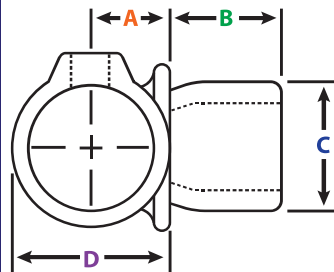

A84-6	0.91	1.22	1.34	1.77		0.73
A84-7	1.10	1.46	1.67	2.17		1.15
A84-8	1.18	1.61	1.88	2.40		1.48

**A85 45° Single Socket Tee**

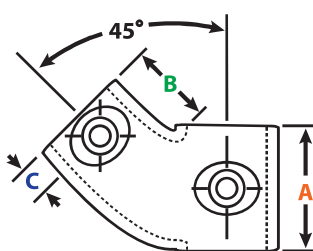

A85-7	2.52	1.55	0.71			1.52
A85-8	2.87	1.79	0.77			2.01

Measurements may vary

**A86 Aluminum Swivel**

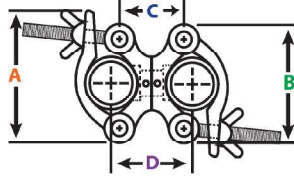

Size Ref.	DIMENSIONS (inches)					WT. LB.
	A	B	C	D	E	
A86-7x7	4.49	3.70	2.13	2.83		2.20
A86-7x8	4.49	3.70	2.13	2.91		2.20
A86-8x8	4.49	3.70	2.13	3.03		2.20

**A91 Adjustable Side Outlet Tee**

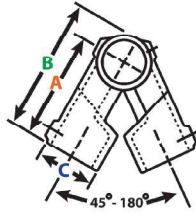

A91-7	3.55	5.31	2.13			2.76
A91-8	3.95	5.91	2.36			3.31

**A96 MOD. Single Swivel Socket Male**

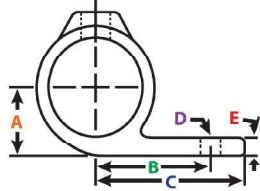

A96-7	1.38	2.09	2.72	0.39	0.39	0.99
A96-8	1.57	2.24	2.99	0.39	0.39	1.21

**A98 MOD. Double Swivel Socket Male**

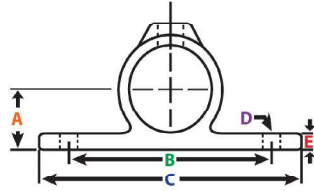

A98-7	1.30	4.25	5.47	0.39	0.39	1.43
A98-8	1.47	4.80	6.02	0.39	0.39	1.65

**CH.HD Clevis Pipe Hanger**

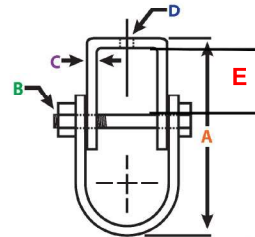

CH.HD-7	3.86	0.39	0.18	0.43		0.66
CH.HD-8	4.25	0.39	0.18	0.43	1.0625	0.71

**TS Tin Strap Hanger**

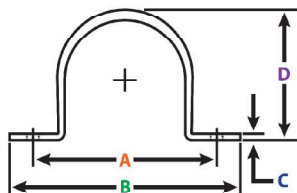

TS-5	2.32	3.19	0.04	1.12		0.04
TS-6	3.29	4.00	0.08	1.36		0.04
TS-7	3.39	4.25	0.08	1.78		0.10
TS-8	3.66	4.57	0.08	2.15		0.11
TS-9	4.25	5.16	0.08	2.50		0.13



# Pipe Load Capacity Chart

Standard Schedule 40 Steel Pipe  
 All Loads are in pounds (lbs)  
 Safety factor of 2:1

Span	3/4" Sch.40	1" Sch.40	1 1/4" Sch.40	1 1/2" Sch.40	2" Sch.40
2'	676	1264	2248	3125	5372
3'	450	843	1500	2083	3581
4'	338	632	1124	1563	2686
5'	270	505	900	1250	2149
6'	225	421	749	1042	1790
7'	193	361	642	893	1537
8'	168	316	562	781	1343
9'	150	281	500	694	1192
10'	134	252	448	625	1074

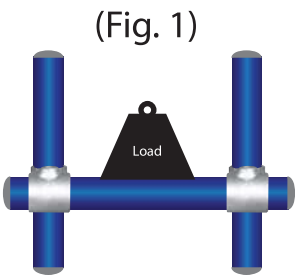

One pipe supporting an evenly distributed load

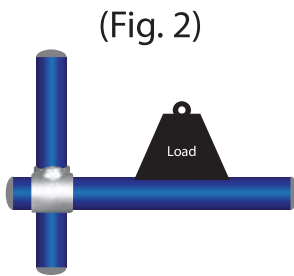

For cantilever pipes with evenly distributed load, all figures to be multiplied by 0.166

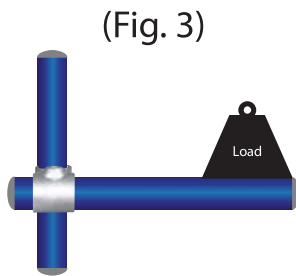

For cantilever pipes with load at end, all figures to be multiplied by 0.083

## LABORATORY TEST REPORT FOR ULTIMATE LOAD OF SET SCREW ON PIPE

Clamp Size Ref.	Nom. Pipe Size	No. of Set screws	Torque (ft.lbs)	Ultimate Load (lbs)	Results
5	3/4"	1	20	1500	Pipe Failure
6	1"	1	20	1600	Pipe Failure
7	1 1/4"	1	20	1750	Pipe Failure
8	1 1/2"	1	20	2200	Pipe Failure
9	2"	1	20	2000	Pipe Failure

Diagram of test method

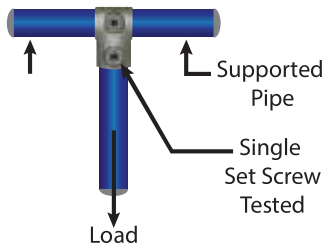

Tests were carried out by an independent laboratory using the following method:

- A single slip-on pipe tee clamp with one case hardened set screw
- Two pieces of Schedule 40 standard black pipe at 24" long

One pipe was inserted into the vertical barrel of the clamp with the set screw tightened to 20 ft lbs torque, as shown in the above diagram. A Baldwin State Universal Testing Machine was used to pull the connections apart to determine the Ultimate Load Capacity. The above test results represent the Ultimate Load Capacity for each of the test conditions shown (**no safety factors are included**). At this point, for each of the listed tests, failure occurred when the set screw would score the pipe, resulting in the pipe being pulled out of the clamp.

To determine pipe and clamp sizes to support a required load, please use the following method:

1. Divide **Ultimate Load Capacity** by the appropriate **safety factor**
2. Refer to the pipe **Load Capacity Chart** above
3. Use the **lower** of the two results